

# VisiFerm™ DO Sensors

## Operating Instructions



# Table of Contents

<b>1</b>	<b>General Information</b>	<b>4</b>
1.1	Intended Use	4
1.2	About this Operating Instruction	4
<b>2</b>	<b>Liability</b>	<b>4</b>
<b>3</b>	<b>Safety Precautions and Hazards</b>	<b>5</b>
3.1	General Precautions	5
3.2	Operation of VisiFerm DO Sensor	5
3.3	Earthing	7
3.4	Electrical Safety Precautions	8
3.5	Chemical, Radioactive or Biological Hazard Precautions	9
<b>4</b>	<b>Product Description</b>	<b>9</b>
4.1	General Description	9
4.2	Hardware Description	10
4.3	Optical DO measurement	11
4.4	VisiFerm DO with micro Transmitter inside	11
<b>5</b>	<b>Installation</b>	<b>11</b>
5.1	Unpacking	11
5.2	Configure the VisiFerm DO with Hamilton Device Manager (HDM)	12
5.2.1	Installing the Hamilton Device Manager	12
5.2.2	Installing DTMs	12
5.2.3	Connecting a VisiFerm DO Sensor to HDM	13
5.2.4	Setting User Level	13
5.2.5	Configuring the VisiFerm DO Sensor Parameters	14
5.2.6	Configuring the calibration settings	15
5.2.7	Configuring the temperature settings of SIP / CIP process	15
5.2.8	Configuring the analog interface for your process control system	16
5.2.9	Defining a measuring point name for identification of the process	16
5.3	Install VisiFerm DO in your Measuring Loop	16
5.3.1	Mechanical Process Connection	16
5.3.2	VP 8 Pin Designation	17
5.3.3	Controlling 4–20 mA current interface signals by pulse-width modulation	18
5.3.4	Electrical Connection for Analog 4–20 mA Connection	19
5.3.5	Electrical connection for the ECS interface	20
5.3.6	Electrical connection for the digital RS485 interface	21
<b>6</b>	<b>Operation</b>	<b>23</b>
<b>7</b>	<b>Maintenance</b>	<b>23</b>
7.1	Verify Sensor Status and ODO Cap Functionality	23
7.2	Replacing the ODO Cap	24
7.3	Calibration	24
7.3.1	Automatic Standard Calibration with HDM	25
7.3.2	Zero Point Calibration (Point Zero Oxygen)	25
7.3.3	Calibration in Air (Calibration Point Air)	26
7.4	Product calibration	26
7.5	Cleaning	28
<b>8</b>	<b>Troubleshooting</b>	<b>28</b>
8.1	Sensor Self-Diagnostic	28
8.1.1	Warnings	29
8.1.2	Errors	30
8.2	Getting Technical Support	31
8.3	Returning VisiFerm DO for Repair	31
<b>9</b>	<b>Disposal</b>	<b>31</b>
<b>10</b>	<b>Ordering Information</b>	<b>32</b>
10.1	VisiFerm DO	32
10.2	Parts and Accessories	32
10.3	Services	36

## Hamilton Warranty

Please refer to the General Terms of Sales (GTS).

## Important note

Copyright © 2017 Hamilton Bonaduz AG, Bonaduz Switzerland. All rights reserved. The reproduction of any part of this document in any form is forbidden without the express written agreement of Hamilton Bonaduz AG.

Contents of this manual can be modified without previous announcement. Technical modifications reserved. Greatest possible care was used on the correctness of the information in this manual. If errors should be discovered nevertheless, Hamilton Bonaduz AG is pleased to be informed about it. Regardless of this, Hamilton Bonaduz AG cannot assume liability for any errors in this manual or for their consequences.



# 1 General Information

## 1.1 Intended Use

The VisiFerm DO sensors are intended for the measurement of dissolved oxygen (DO).

If the sensor is used in contact with gaseous or liquid organic solvents, the resulting measurement accuracy in this application must be separately checked and validated by the customer.

**⚠ ATTENTION! VisiFerm DO is not intended for hazardous atmospheres.**

The VisiFerm DO sensor has a built-in temperature sensor (NTC 22 kOhm). This temperature sensor is to be used only for monitoring the sensor conditions, not for controlling the process temperature.

## 1.2 About this Operating Instruction

These Operating Instructions are designed to support the integration, operation and qualification of the VisiFerm DO (ECS) and VisiFerm DO Arc sensors.

To achieve this, it will describe the features of VisiFerm DO (ECS) and VisiFerm DO Arc and its integration in Process Control Systems (PCS). Both the hardware and the communication between the VisiFerm DO and Process Control Systems are detailed in this manual. After reading this manual the user should be capable of installing and operating VisiFerm DO sensors.

**⚠ ATTENTION! Essential information for avoiding personal injury or damage to equipment.**

**📄 NOTE: Important instructions or interesting information.**

# 2 Liability

The liability of Hamilton Bonaduz AG is detailed in the document "General Terms and Conditions of Sale and Delivery".

Hamilton is expressly not liable for direct or indirect losses arising from use of the sensors. It must in particular be insured in this conjunction that malfunctions can occur on account of the inherently limited useful life of sensors contingent upon their relevant applications. The user is responsible for the calibration, maintenance and regular replacement of the sensors. In the case of critical sensor applications, Hamilton recommends using back-up measuring points in order to avoid consequential damages. The user is responsible for taking suitable precautions in the event of a sensor failure.



**📄 NOTE:** The VisiFerm DO sensor is not intended and specified as a safety device. A SIL (Safety Integrity Level) certification is not available. It is in the sole responsibility of the user to validate the VisiFerm DO sensor according to the safety requirements of his application.

# 3 Safety Precautions and Hazards

**⚠ ATTENTION! Read the following safety instructions carefully before installing and operating the VisiFerm DO sensor.**

## 3.1 General Precautions

For safe and correct use of VisiFerm DO, it is essential that both operating and service personnel follow generally accepted safety procedures as well as the safety instructions given in this document, the VisiFerm DO operation instruction manual.

The specification given in the "Specification Sheet" as regards temperature, pressure etc. may under no circumstances be exceeded. Inappropriate use or misuse can be dangerous.

The lifetime of the VisiFerm DO highly depends on the specific conditions of the application. Temperature, pressure, chemicals used may accelerate the ageing of both the sensor and its ODO cap. See chapter 7 for replacement conditions.

Cleaning, assembly and maintenance should be performed by personnel trained in such work. Before removing the sensor from the measuring setup, always make sure the no process medium can be accidentally spilled. When removing and cleaning the sensor, it is recommended to wear safety goggles and protective gloves.

The sensor can not be repaired by the operator and has to be sent back to Hamilton for inspection.

Necessary precautions should be taken when transporting the sensors. For repair or shipment the sensor should be sent back in the original reusable packaging box. Every VisiFerm DO sent back for repair must be decontaminated.

If the conditions described in these operating instructions manual are not adhered to or if there is any inappropriate interference with the equipment, all of our manufacturer's warranties become obsolete.

## 3.2 Operation of VisiFerm DO Sensor

VisiFerm DO sensors must be used for their intended applications, and in optimum safety and operational conditions. The specifications (such as temperature or pressure) defined in the "Specification Sheet" must not be exceeded under any circumstances (Visit [www.hamiltoncompany.com](http://www.hamiltoncompany.com) for Specification Sheet).

Make sure that the PG13,5 thread and the O-ring are not damaged when screwing the sensor into the process. O-rings are consumable parts which must be exchanged regularly (at least once per year). Even when all required safety measures have been complied with, potential risks still exist with respect to leaks or mechanical damage to the armature. Wherever there are seals or screws, gases or liquids may leak out undetected. Always make sure that no process medium can be accidentally spilled before removing the sensor from its measurement setup. Do not put stress on the system by vibration, bending or torsion.

Before use, verify that the sensor is properly configured for your application.

**⚠ ATTENTION! When unscrewing the PG13,5 thread connection never turn the sensor at the connector head because you can loosen the ODO Cap from the sensor shaft and fluid can reach the interior of the sensor.**

**⚠ ATTENTION! To avoid humidity problems, make sure that the ODO Cap is always attached firmly to the sensor shaft, and that the O-ring between the shaft and cap is undamaged.**

The integrated 4–20 mA analog output has been configured according to factory defaults. You can find full details, including serial number and most important specifications, on the certificate provided with each sensor. Before use, verify that the sensor is properly configured for your application.

Make sure that following cross sensitivities and resistances of ODO Caps are respected.

#### Cross sensitivities and resistances of ODO Cap H0

Measurement not influenced by	Carbon Dioxide
Wetted parts resistant to	Ethanol
Wetted parts not resistant to	Chlorine, Ozone and Organic Solvents such as Acetone, Tetrahydrofuran (THF*)

#### Cross sensitivities and resistances of ODO Cap H2

Measurement not influenced by	Carbon Dioxide, lipophilic compounds
Wetted parts resistant to	Organic Solvents such as Ethanol*, Acetone*, (THF*), Heptan*, Dimethylformamide*
Wetted parts not resistant to	Chlorine and Ozone Gases

\*Tested for 30 min at 25°C

If the sensor is used in contact with gaseous or liquid organic solvents, the resulting measurement accuracy in this application must be separately checked and validated by the customer.

## 3.3 Earthing

The sensor has to be mounted at the mounting location electrostatically conductive ( $< 1\text{M}\Omega$ ). It is recommended to assign the sensor shaft and VP 8 cable shield to earth (PE potential equalization) especially in electromagnetically noisy environments. This significantly improves noise immunity and signal quality. The VP 8 thread is connected to the metallic housing of the VisiFerm DO sensor. Two options for connecting the sensor to the process environment are available.

### Option 1: The Metal tank is connected to earth

The sensor shaft is connected to the metal tank over the PG13,5 thread.

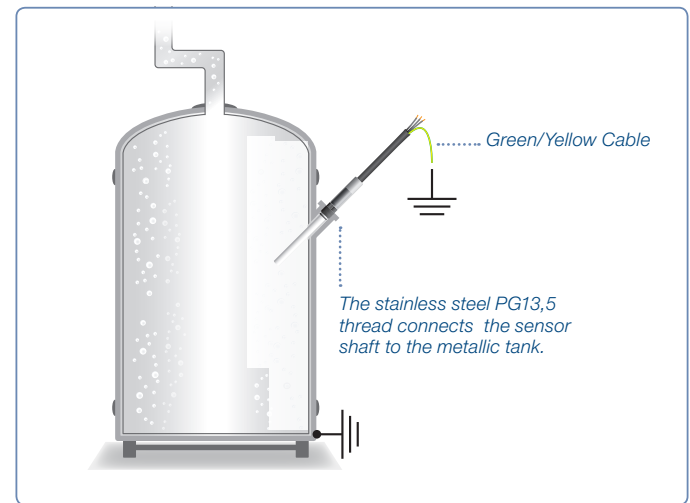

Figure 1: Metal tank with earth connection.

**NOTE:** If the tank is not connected to earth, Option 2 has to be applied.

### Option 2: Glass or plastic tank (not connected to earth)

The glass or plastic tank has no connection to earth and therefore it is necessary to connect the sensor shaft via a screw clamp or VP 8 cable to earth.

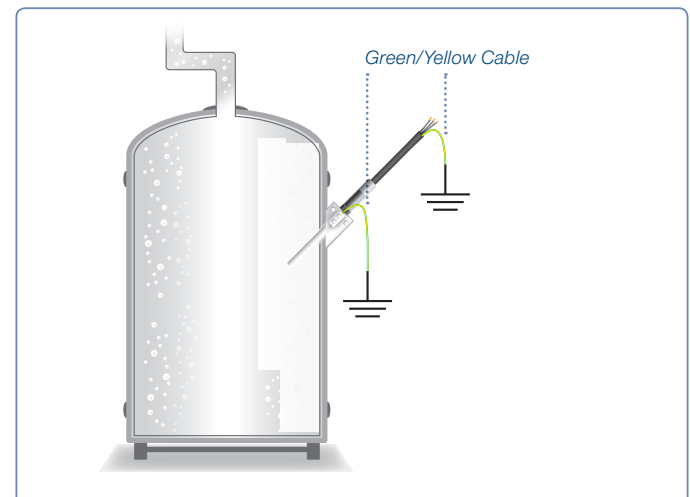

Figure 2: Glass or plastic tank without earth connection.

Below several examples how to connect the shaft of the sensor directly to earth as required in Figure 2 are shown.



Figure 3: Example clamps for connecting the earth to armature and metallic housing of the tank.

### 3.4 Electrical Safety Precautions

Do not connect the sensor to a power source of any voltage beyond the range stated in the power rating Technical Specifications ([www.hamiltoncompany.com](http://www.hamiltoncompany.com)).

Always use Hamilton VP 8 cables for safe connection. Cables are available in a broad range of lengths (Chapter 10). Make sure the cable is intact and properly plugged to avoid any short circuit.

Keep VisiFerm DO away from other equipment which emits electromagnetic radio frequency fields, and minimize static electricity in the immediate environment of the optical measuring parts. Carefully follow all the instructions in chapter 5.3 to avoid electrical damage to the sensor. The contacts must be clean and dry before sensor is connected to the cable.

**⚠ ATTENTION! Switch off the power supply and unplug the connector before dismantling the VisiFerm DO.**

### 3.5 Chemical, Radioactive or Biological Hazard Precautions

Selection of the appropriate safety level and implementation of the required safety measures for working with VisiFerm DO is the sole responsibility of the user.

If working with hazardous liquids observe and carry out the maintenance procedures, paying particular attention to cleaning and decontamination. If VisiFerm DO becomes contaminated with biohazardous, radioactive or chemical material, it should be cleaned. Failure to observe and carry out the maintenance procedures may impair the reliability and correct functioning of the measuring module.

## 4 Product Description

### 4.1 General Description

The VisiFerm DO was the first optical dissolved oxygen (DO) sensor for process measurement. With their micro transmitter, VisiFerm DO sensors enable direct communication to the process control system via 4–20 mA standard signal or digital Modbus. Wireless communication with the Arc Wireless Adapter may be used for monitoring, configuration and calibration, and saves time without compromising the quality of the wired connection.

The sensor features furthermore an integrated Bluetooth 4.0, enabling in this way wireless data exchange with smartphones and tablets.

VisiFerm DO optical technology improves the measuring performance and simplifies maintenance. Improvements compared to conventional electrochemical (amperometric) sensors include flow independence, rapid start-up with no polarization time, and simplified maintenance.

With the transmitter integrated, VisiFerm DO sensors provide more reliable measurements directly to your process control system. The  $\mu$ -transmitter located in the sensor head stores all relevant sensor data, including calibration and diagnostic information, simplifying calibration and maintenance. The integrated quality indicator predicts the remaining sensor and cap life time.

Key benefits include:

- Optical measurement
- No separate transmitter needed
- Simple maintenance with robust industrial design
- Easy to install
- Direct digital Modbus or analog communication to the process control system via 4–20 mA standard signal.
- Full online wireless option via Bluetooth 4.0 for easy monitoring, configuration and calibration

## 4.2 Hardware Description

The VisiFerm DO sensor consists of a sensor head with integrated electronic and a sensor shaft in contact with the measured medium. The sensor shaft is terminated by the optical dissolved oxygen (ODO) cap, carrying the oxygen sensitive luminophore. During development, special attention was paid to an optimum sanitary design. All materials in contact with the solution meet the FDA requirement.

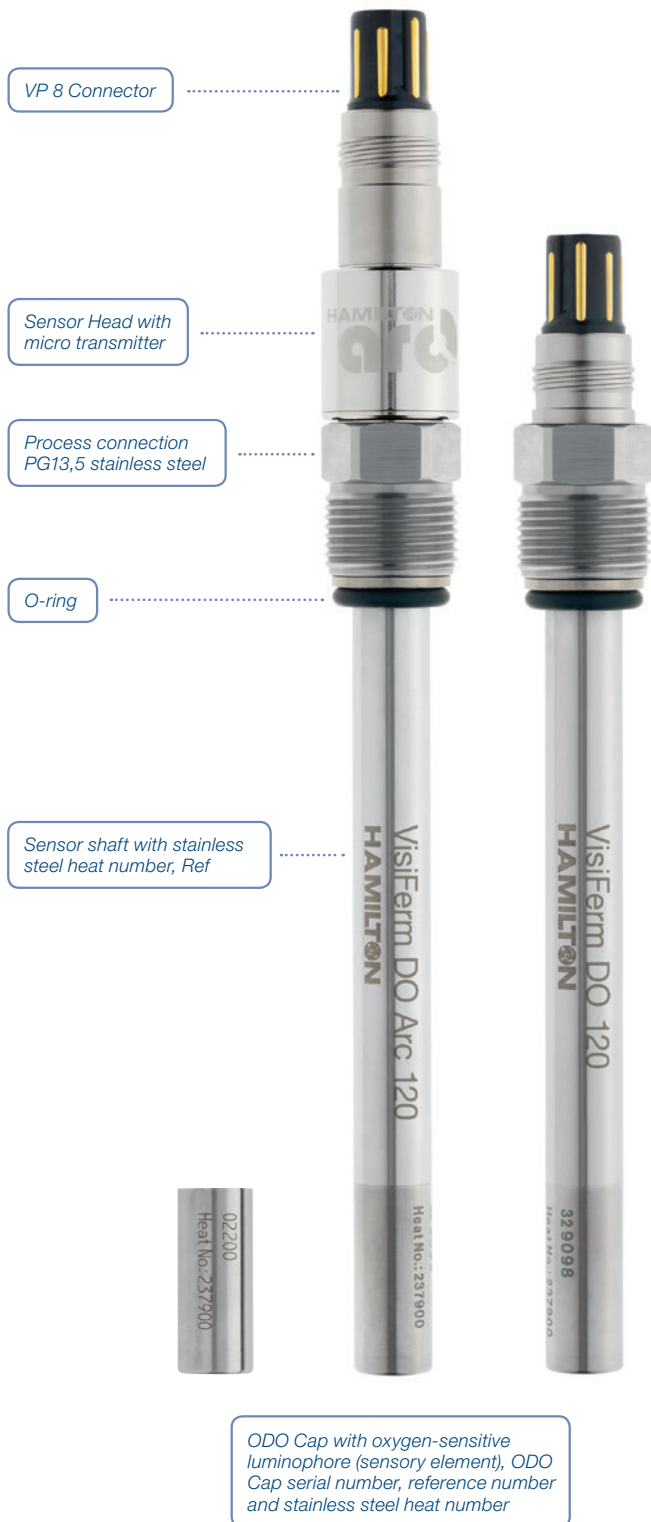

Figure 4: VisiFerm DO Arc and VisiFerm DO hardware description.



## 4.3 Optical DO measurement

The optical measurement principle is based on the so-called luminescence quenching. The luminescence of certain organic pigments (luminophore) is quenched in the presence of oxygen. The luminophore absorbs the excitation light and release a part of the absorbed energy by emission of fluorescence. In the presence of oxygen, energy transfer takes place from the excited luminophore to oxygen. The luminophore does not emit fluorescence and the measurable fluorescence signal decreases.

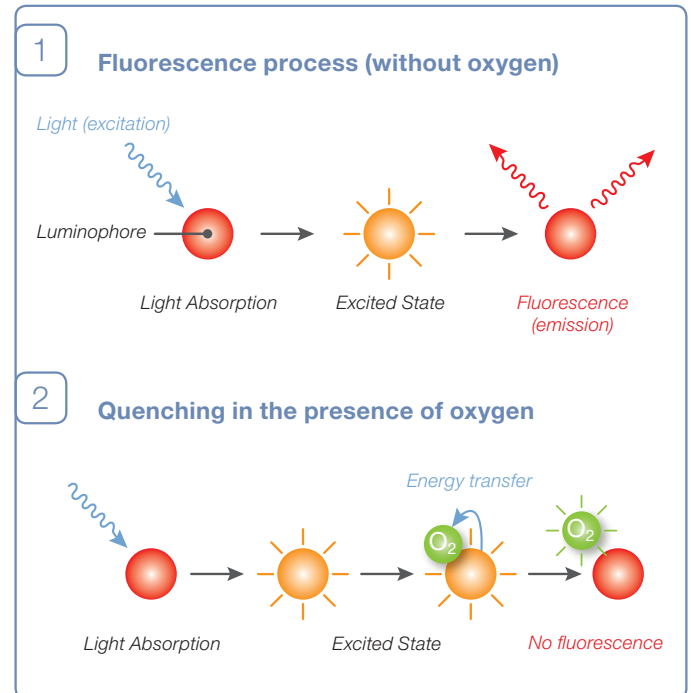

Figure 5: Fluorescence quenching by oxygen.

## 4.4 VisiFerm DO with Micro-Transmitter inside

With the micro-transmitter integrated, VisiFerm DO sensors offer fully compensated signal directly to the process control system. Communication protocols include standard analog 4–20 mA. The micro transmitter located in the sensor head stores all relevant sensor data, including calibration and diagnostic information, simplifying calibration and maintenance.

## 5 Installation

### 5.1 Unpacking

- 1) Unpack carefully the VisiFerm DO sensor. Enclosed you will find the VisiFerm DO sensor, the Declaration of Quality, the VisiFerm DO Instruction Manual, and the Stainless Steel material Certificate.
- 2) Inspect the sensor for shipping damages or missing parts.





Figure 6: VisiFerm DO delivery package.

## 5.2 Configuring the VisiFerm DO with Hamilton Device Manager (HDM)

Two pieces of software are required to configure and set up the VisiFerm DO sensor. The Hamilton Device Manager (HDM) software is required as frame application based on FDT (Field Device Tool). The Device Type Manager (DTM) file is required to configure and manage all VisiFerm DO sensors in HDM. To configure the VisiFerm DO sensor you will need a Wireless Converter, Arc Wireless Adapter and power supply.

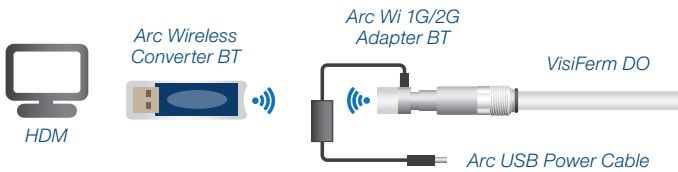

Figure 7: VisiFerm DO configuration with HDM.

### 5.2.1 Installing the Hamilton Device Manager

- 1) Download the ZIP file "Hamilton Device Manager" from the Hamilton webpage [www.hamiltoncompany.com](http://www.hamiltoncompany.com) (search for Hamilton Device Manager).
- 2) Unpack the downloaded ZIP-File.
- 3) Install the "Hamilton Device Manager" by double clicking "setup.exe" and follow the instructions on the screen.

### 5.2.2 Installing DTMs

- 1) Download the Zip File «Arc Sensor DTM Setup» from the Hamilton webpage [www.hamiltoncompany.com](http://www.hamiltoncompany.com) (search for Hamilton DTMs).
- 2) Unpack the downloaded ZIP-File.
- 3) Do not plug the Wireless Converter before the installation of the DTM is completed.
- 4) Install the DTM and follow the instructions on the screen.

- 5) Plug your Wireless Converter to the USB-port of your computer. The driver installs automatically under Windows® 7. Use the "Found new Hardware" Wizard to install the drivers saved on the computer under Windows® XP.

### 5.2.3 Connecting a VisiFerm DO Sensor to HDM

- 1) Connect the sensor to the power supply using the Sensor Power Cable.
- 2) Start HDM.
- 3) Open "Device Catalogue" in View.
- 4) Update the DTM Device Catalogue by clicking "update".
- 5) Add the selected "Modbus Wireless Port". Right click on "My network" and select "Add" for the Device Type.
- 6) The Modbus Wireless Port is added to the "My network" list.
- 7) Double click on the "Modbus Wireless Port". Set the appropriate COM Port and validate with "Apply".
- 8) "Scan for devices". The available sensors appear on the Network View.
- 9) Select the desired sensor. Right click and select "GO online". The sensor is online if it shows in bold font and offline if it shows in normal font.

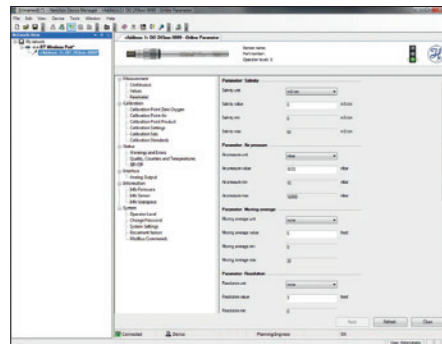

Figure 8: VisiFerm DO Sensor connected to the HDM (symbolic figure).

### 5.2.4 Setting User Level

- 1) Select the desired sensor and check it is online. If not "Go online" with right click on the sensor.
- 2) Double click on the bold sensor name.
- 3) Set the appropriate operator level and press "Apply".

Parameter Name	Description	Default password	Configuration	Location
User [U]	The Users can only read basic data from sensor	Not required	Not required	System
Administrator [A]	The Administrators can also calibrate sensors	18111978	Not required	System
Specialist [S]	Additionally the specialist can configure the sensors.	16021966	Must	System

Figure 9: User levels.



### 5.2.5 Configuring the VisiFerm DO Sensor Parameters

- 1) Select the desired sensor and check it is online. If not "Go online" with right click.
- 2) Double click on the bold sensor name.
- 3) Set operator level to "S" and press "Apply" (Chapter 5.2.4).
- 4) Configure the measurement parameters.

Parameter Name	Description	Default Value	Configuration	Location
DO Unit	These are the measurement physical units	%vol. %sat. ug/l ppb mg/l ppm mbar	Required	Measurement/ Values
T unit	These are the temperature physical units	K °F °C	Required	Measurement/ Values
Salinity	The concentration of dissolve oxygen in saturated water is dependent on the salinity	0 mS/cm	Default parameter recommended	Measurement/ Parameter
Air pressure	The partial pressure of oxygen is proportional to the atmospheric pressure or the pressure of the air supply to the process	1013 mbar	Required, application dependent	Measurement/ Parameter
Measuring interval*	The measuring interval can be set between 1 sec. and 300 sec. The LED flashes once in the set measure interval	3 sec.	Recommended default parameter	Measurement/ Parameter
Moving average	The sensor uses a moving average over the measuring points	0 (auto)	Recommended default parameter	Measurement/ Parameter
Sensing Material	Sensing Material are different types of ODO Cap which can be set by entering the Ref number of the ODO Caps	243515	Must application dependent	Measurement/ Parameter

\* In calibration mode the sensor will automatically switch to 3 sec sampling rate after the first calibration.

### 5.2.6 Configuring the calibration settings

Parameter Name	Description	Default Value	Configuration	Location
Drift DO	Higher drift will interrupt the calibration process. Warning comes up "drift oxygen"	0.05%/min	Recommend default parameter	Calibration/ Calibration Settings
Drift T	Higher drift will interrupt the calibration process. Warning comes up "drift temperature"	0.5 K/min	Recommend default parameter	Calibration/ Calibration Settings

### 5.2.7 Configuring the temperature settings of SIP / CIP process

Parameter Name	Description	Default Value	Configuration	Location
Customer temperature range	User defines temperature range for DO reading. No DO reading above 85°C possible	-10°C to 85°C	Recommend default parameter	Status/ Quality, Counters and Tempe- ratures
SIP process definition	User defines conditions for the SIP counter	Temp. min: 120°C Temp. max. 130°C Time: 20 min	Recommend default parameter	Status / SIP / CIP
CIP process definition	User defines conditions for CIP counter	Temp. min: 80°C Temp. max. 100°C Time: 20 min	Recommend default parameter	Status / SIP / CIP
CIP Com- pensation	Fix offset (phase shift in degrees) which corrects a CIP-driven sensor shift. It may be used where the CIP process is reproducible (Figure 7)	Off	Recommend default parameter	Status / SIP / CIP

Offset in (ppb)	Phase shift (°)
5	0.05
10	0.1
20	0.2
30	0.3
50	0.5
80	0.8
100	1.0
200	1.9
500	4.6

Figure 10: Conversion table to translate the ppb offset in phase degree for 100% ODO cap quality.





## 5.2.8 Configuring the analog interface for your process control system

Parameter Name	Description	Default Value	Configuration	Location
Interface Mode	The output of the ECS/4-20 mA can be configured linear, bilinear or with a fix value	ECS mode/ 4-20 mA	Recommended default	Interface/ Analog
Value at 0 nA / 4 mA	Defined measurement value for 0 nA/ 4 mA output	0 %sat.	Must application dependent	Interface/ Analog Output
Value at 60 nA / 20 mA	Defined measurement value for 60 nA/ 20 mA output	300 %sat.	Must application dependent	Interface/ Analog Output
Mode in event of warning	Current output mode in case of warnings	No output	Recommended default parameter	Interface/ Analog Output
Mode in event of errors	Current output mode in case of errors	Continuous output	Recommended default parameter	Interface/ Analog Output
Output in event of warning	Current output in case of warnings	433 nA/ 3.5 mA	Recommended default parameter	Interface/ Analog Output
Output in event of error	Current output in case of error	466 nA/ 3.5 mA	Recommended default parameter	Interface/ Analog Output
Output for T out of limit	Current output in case of temperature out of limit	499 nA/ 3.5 mA	Recommended default parameter	Interface/ Analog Output

Before installing the armatures, you should test that the seal is tight and the parts are all in working order. Ensure that there is no damage to the sensor or the armature. Check whether all O-rings are in place in the appropriate grooves and are free of damage. To avoid any mechanical damage to O-rings on assembly, they should be slightly greased.

Please note that O-rings are wetted parts and greasy compounds must comply to your FDA application needs.

## 5.3.2 VP 8 Pin Designation

Always use Hamilton VP 8 sensor cables for safe connection, which are available in different lengths (Chapter 10).



Figure 11: Requirements for electrical connection of VisiFerm DO sensors.

## 5.2.9 Defining a measuring point name for identification of the process

Parameter Name	Value	Default Settings	Location	Descriptions
Measuring point	User can define a sensor name for better identification of the measuring point	243666-111-1234	Optional	Information / Info Userspace

## 5.3 Install VisiFerm DO in your Measuring Loop

### 5.3.1 Mechanical Process Connection

The VisiFerm DO mechanical design is compatible with all Hamilton process housings, including FlexiFit, Retractable, RetractoFit and Hygienic Sockets.

VP pin	Function	Color Double Coaxial Cable	Color Data Cable
A	ECS mode: cathode (only in ECS mode)	Coaxial core black transparent	Yellow
B	- 4 – 20 mA interface (mA interface #1). - ECS mode: anode. Never connect in the ECS mode with + 2 V or more!	Coaxial shield black	Green
C	Power supply: + 24 VDC (7 to 30 VDC) Start-up power: 1 W Continuous power consumption: 600 mW	Coaxial core red transparent	Red
D	Power supply: Ground	Coaxial shield red	Blue
E	Temperature sensor NTC 22 kOhm for ECS mode	White	Brown
F	Temperature sensor NTC 22 kOhm for ECS mode	Green	White
	RS485 (A)	Yellow	Gray
	RS485 (B)	Brown	Pink
Shaft	Sensor shaft connected to earth	Green/Yellow	Green/ Yellow



### 5.3.3 Controlling 4–20 mA current interface signals by pulse-width modulation

Hamilton VisiFerm DO sensors use the method of pulse-width modulation (PWM) to adjust the DC currents of the 4–20 mA interfaces corresponding to the measured values. In principle, the pulse width ( $t_i$ ) of a rectangular signal with a constant frequency, the pulse duty factor ( $t_i/T$ ), is modulated and afterwards demodulated by a low-pass filter to generate continuous analog DC signals. The resulting value  $y_i$  corresponds to the average of the PWM signal (see Figures 12 and 13). The PWM-loads of the Sensors have low-pass filters which are not able to eliminate all AC fractions of the used PWM frequency of 5 kHz due to technical impossibilities. Therefore, the current signals of the 4–20 mA interfaces are still overlaid by a certain AC which should be masked by lag smearing or input filters of the current input card of the process control system (PCS). Recommended PCS settings are a sampling rate below 3.5 kHz, an averaging over more than 1 s, and the use of galvanically separated inputs to avoid oscillations. It is also possible to use mathematical functions or isolating amplifiers for signal processing filtering if necessary. For detailed technical advice about suitable isolating amplifiers, please contact Hamilton technical support.

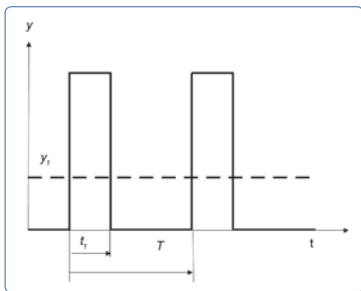

Figure 12: Progress of a rectangular signal with a period  $T$  and a pulse duration  $t_i$  for the generation of an analog signal with the value  $y_i$ .

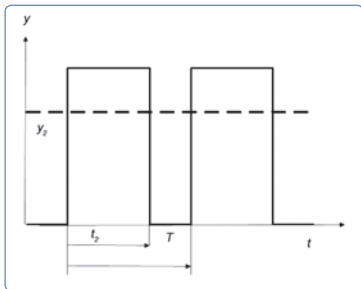

Figure 13: Progress of a rectangular signal with a period  $T$  and a pulse duration  $t_i$  for the generation of an analog signal with the value  $y_2$ .

**⚠ ATTENTION! The Arc sensor and VisiFerm DO generates the 4-20 mA signals by pulse with modulation (PWM) which is not compatible to all PCS systems. Also a galvanic separation between the power supply and the PCS is necessary for correct sensor functionality when used in 4-20 mA setups. Figure 12 illustrates a solution for the problem.**

#### Analog interface 1 and 2

Galvanically not isolated, pulse width modulation with 5 kHz, recommended PCS settings:

- Use galvanically separated inputs
- Sampling rate < 3 kHz and  $\neq n \cdot 3.5$  kHz
- Average over > 1 s

### 5.3.4 Electrical Connection for Analog 4–20 mA Connection

The 4–20 mA interface enables direct connection of the VisiFerm DO sensor to a data recorder, indicator, control unit or PCS with analog I/O. The VisiFerm DO works as a current sink sensor and is passive. Connect the sensor according to the pin designations (Chapter 5.3.2). The 4–20 mA interface of the VisiFerm DO sensors is pre-configured with default values for the 4–20 mA range, and measurement unit. Configure the 4–20 mA interface according to your requirements for proper measurement (Chapter 5.2.8).

#### Examples of circuit arrangement

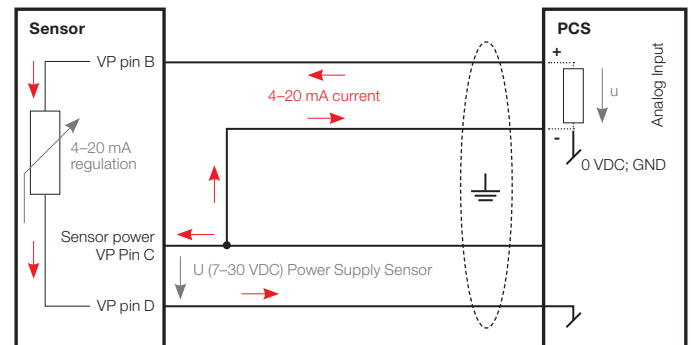

Figure 14: Three-wire loop wiring diagram for the 4–20 mA interface.

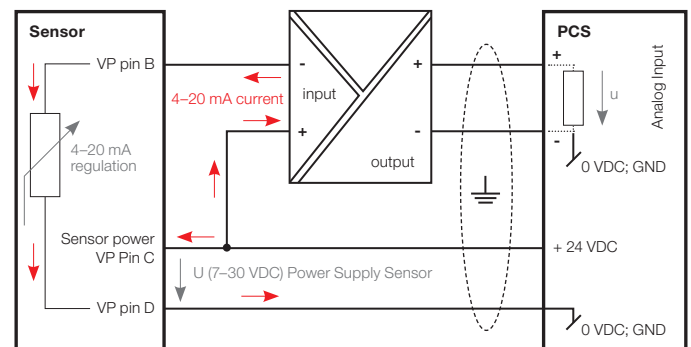

Figure 15: The safest form of wiring, using an external isolation amplifier. The figure represents 4–20 mA interface. (For detailed technical advice, please contact the technical support at Hamilton.)

When using the 4–20 mA interface, pins have the following designation with respect to VP cable conductor colors:

VP pin	Function	Color Double Coaxial Cable	Color Data Cable
A	not used	Coaxial core black transparent	Yellow
B	- 4 – 20 mA interface (mA interface #1)	Coaxial shield black	Green
C	Power supply: +24 VDC (7 to 30 VDC) Start-up power: 1 W Continuous power consumption: 600 mW	Coaxial core red transparent	Red
D	Power supply: Ground	Coaxial shield red	Blue



### 5.3.5 Electrical connection for the ECS interface

The ECS mode enables the simulation of an electrochemical sensor. Thus a VisiFerm DO sensor can be connected to classical measuring devices instead of amperometric oxygen sensors (Clark cells). Furthermore only the power supply of the VisiFerm DO sensor is necessary.

**NOTE:** The ECS mode is only available for VisiFerm DO ECS and not for VisiFerm DO Arc sensors.

**ATTENTION!** Do not apply any high voltage (max. 2 VDC) at pin B (anode)! This can result in a destruction of the sensor in ECS mode! Note: Only in 4-20 mA mode a high voltage (max. 24 VDC) may be applied in order to operate the current interface!

In an electromagnetically noisy environment, it is advisable to assign the sensor's shaft and/or VP cable shield to earth. This significantly improves noise immunity and signal quality.

The NTC temperature sensor attached to the pins E and F is isolated from the integrated electronics and is used for the temperature compensation of the oxygen signal in the measuring device.

Usually classical sensors are operated with a polarization voltage between anode and cathode. This polarization voltage is supplied by the measuring device. VisiFerm DO can be operated with polarization voltages usual for electrochemical sensors. The sensor is optimized for a polarization voltage of -675 mV.

For adjustment to different measuring devices and/or for simulation of different amperometric sensors the current can be adjusted between 0 and 500 nA.

When using the ECS interface, pins have the following designations with respect to VP cable conductor colors:

VisiFerm DO	VP pin	Color Double Coaxial Cable
Cathode	A	Coaxial core black transparent
Anode <b>ATTENTION:</b> In ECS mode never connect with a potential higher as + 2 V	B	Coaxial shield black
Power supply: + 24 VDC (7 to 30 VDC), max. 1000 mW	C	Coaxial core red transparent
Power supply: Ground	D	Coaxial shield red
NTC 22 kOhm	E	White
NTC 22 kOhm	F	Green
sensor shaft (connect with the mass of the power supply)	shield	Cable shield green-yellow

### Example of circuit arrangement

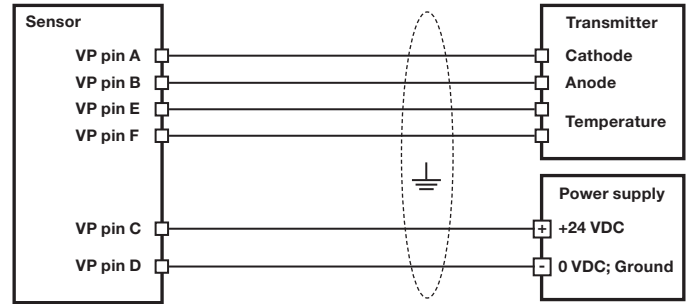

Figure 16: Wiring diagram for the ECS interface.

### 5.3.6 Electrical connection for the digital RS485 interface

The digital RS485 interface enables communication with VisiFerm DO and Arc sensor for performing measurements, for calibrating the sensor and for changing the sensor's configuration parameters. VisiFerm DO and Arc sensors are always connected to digital controlling devices as a Modbus slave. To function, they require a power supply (VP 8 pins C and D, see below). The section entitled "Configuring the VisiFerm DO parameters" describes operation in digital mode.

#### Additional information:

The Modbus RTU communication protocol corresponds to the Modbus-IDA standard (see [www.modbus.org](http://www.modbus.org)). VisiFerm DO uses an open register set developed by Hamilton. Additional information about the register content and structure can be found in the programmers manual under [www.hamiltoncompany.com](http://www.hamiltoncompany.com)

The Modbus physical layer is described in detail with requirements on cabling and line termination in the "Modbus Serial line Protocol and Implementation Guide" [www.modbus.org](http://www.modbus.org) → Technical Resources / Modbus Specifications / Modbus Serial line Protocol and Implementation Guide.

**ATTENTION!** Because all sensors are delivered with factory-default settings, each sensor must be configured for its specific application before first use (see the section entitled "Configuring VisiFerm DO").

The pins for digital the RS485 interface have the following designation with respect to VP cable conductor colors:

VisiFerm DO	VP pin	Color Double Coaxial Cable	Color Data Cable
Power supply: +24 VDC (7 to 30 VDC), max. power consumption 1 W.	C	Coaxial core red transparent	Red
Power supply: Ground	D	Coaxial shield red	Blue
RS485 (A)	G	Yellow	Gray
RS485 (B)	H	Brown	Pink
Sensor shaft	Shield	Green/Yellow	Green/Yellow



In an electromagnetically noisy environment, it is advisable to connect the VP cable shield to the earth. This significantly improves noise immunity and signal quality.

**Example of circuit arrangement**

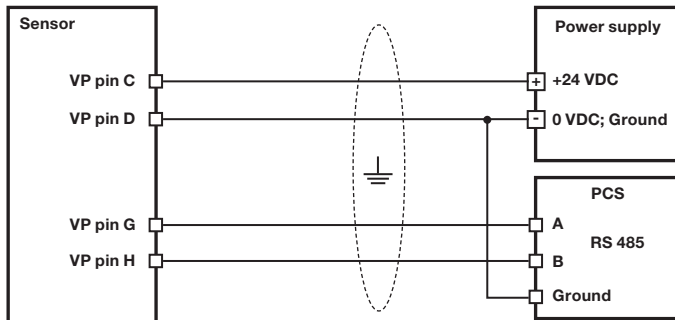

Figure 17: Wiring diagram for the RS485 interface.

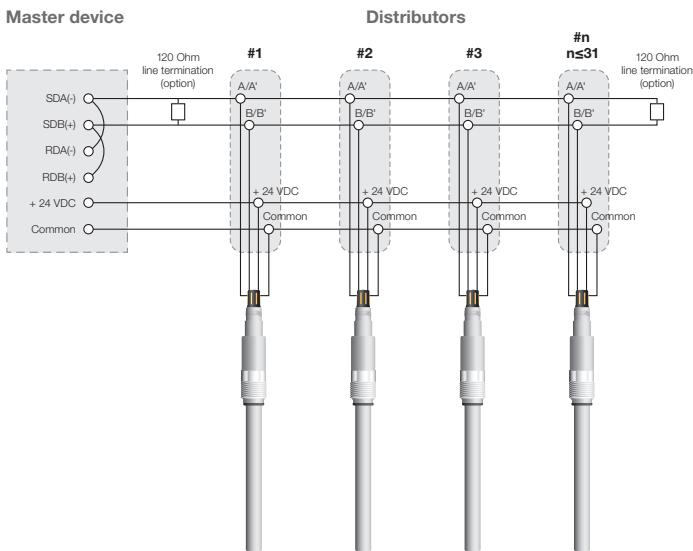

Figure 18: Multi-drop bus wiring for the Modbus two-wire mode. Each sensor functions as a Modbus slave.

# 6 Operation

**WARNING:** Only use the sensor within the specifications (Chapter 10). Failure to do so may lead to damages or measurement failure.

- 1) Remove the protective caps from the VisiFerm DO shaft, and from the VP 8 sensor head
- 2) Check the O-ring on the sensor shaft and verify if the ODO Cap is screwed firmly to the sensor shaft (Chapter 7.2)
- 3) Verify if the sensing material is correct for the ODO Cap type which can be set by entering the Ref number of the ODO Caps
- 4) Verify the functionality of the sensor including the ODO cap (Chapter 7.1)
- 5) Calibrate the sensor (Chapter 7.3)
- 6) Connect the sensor to the process control system (Chapter 5.3)
- 7) Verify the measurement in air on your control system
- 8) Mount the sensor to the armature or process connection (Chapter 5.3)

**NOTE:** No oxygen measurement is performed at a temperature higher than 85°C to protect the optoelectronics and enhanced the sensor lifetime.

**NOTE:** To ensure a correct measurement by changing a ODO Cap type e.g. ODO Cap H0 the reference number of the ODO Cap should be configured in the Sensing Material register (See chapter “Configuring the VisiFerm DO Sensor Parameters”. Firmware version ODOUM043. hex or higher is required.

# 7 Maintenance

Periodic maintenance routines need to be run in order to ensure safe and reliable operation and measurement of sensor and the accessories.

**⚠ ATTENTION! Avoid any contact of the equipment with corrosive media.**

## 7.1 Verify Sensor Status and ODO Cap Functionality

- 1) Power the sensor with the Sensor Power Cable and connect the sensor to HDM.
- 2) Control the traffic lights (Figure 19).
- 3) Please refer to the troubleshooting (Chapter 8) for the next steps if the traffic light is not green.

**NOTE:** In order to avoid signal reflection on the lines the use of line termination resistors (120 Ohm each) is recommended. The effect of signal reflections becomes more relevant with long cable length and/or high baud rates.

**NOTE:** In the connection scheme shown above, each sensor must have the unique Modbus device address for proper communication.

The serial Modbus connection between the RS485 port of the master and the corresponding interfaces of the sensors has to be ensured according to the EIA/TIA RS485 standard. Only one sensor can communicate with the master at any time.



- 4) Control the quality of the ODO cap in Sensor Status / Quality Counter and Temperature / Quality Indicator and change the ODO Cap or sensor if required (Chapter 7.2).

**NOTE:** The lifetime of the VisiFerm DO highly depends on the specific conditions of the application. Temperature, pressure, chemicals used may accelerate the ageing of both the sensor and its ODO cap. A warning “DO Replace Sensor Cap” remains active as long as the sensor quality is below 35%. Make sure that after new cap replacement the sensor reaches at least 60% cap quality. The quality indicator takes sensor and cap into account.

- The sensor is performing correctly. No errors or warnings have been registered.
- At least an error or a warning has been registered. Verify the sensor errors and warnings in Sensor Status.
- No communication between the sensor and the HDM. This may be due to a hardware failure.

Figure 19: Description of the traffic lights on the HDM.

## 7.2 Replacing the ODO Cap

The exchange of ODO Cap can be performed very easily:

- 1) Unscrew the ODO Cap from the shaft (Figure 20).
- 2) Exchange the O-ring.
- 3) Screw firmly the new ODO Cap onto the sensor shaft again.
- 4) Perform sensor calibration (Chapter 7.3).

**NOTE:** If the ODO Cap is mounted very firmly on the shaft, and if you cannot obtain a good grip on the stainless steel with your fingers, a silicone tube between your fingers and metal may supply a better grip.



Figure 20: Replacing the ODO Cap.

## 7.3 Calibration

The VisiFerm DO sensors provide two kinds of sensor calibration: automatic standard calibration, and product calibration. The automatic standard calibration and the product calibration may be performed using HDM (see chapter 5.2).



### 7.3.1 Automatic Standard Calibration with HDM

VisiFerm DO sensors are calibrated at two points: in air and in an oxygen-free environment. During calibration, the sensor controls automatically the stability of the oxygen and temperature signals.

**NOTE:** For greater measurement accuracy ensure that temperature difference between calibration medium and process medium is minimal.

### 7.3.2 Zero Point Calibration (Point Zero Oxygen)

- 1) Power the sensor with the M12 Sensor Power Cable and connect it to HDM.
- 2) Select the sensor to calibrate in “Network View”.
- 3) Go in System and select “Operator Level”.
- 4) Log in an appropriate Operator Level (Administrator or Specialist). More details in chapter 5.2.4.
- 5) Go to Calibration and select “Point Zero Oxygen”.
- 6) Immerse the sensor into an oxygen-free environment (Figure 21) for e.g. nitrogen gas with 5.0 purity (99.999%) and nitrogen flow rate: 0.5 L/min with 3 to 4 bar pressure (no overpressure). Let the system equilibrate and ensure stable conditions for at least three minutes.
- 7) Select the calibration command “Auto” and press “Apply”.
- 8) Verify the Calibration status in Zero Oxygen. It should indicate “Calibration successful”.

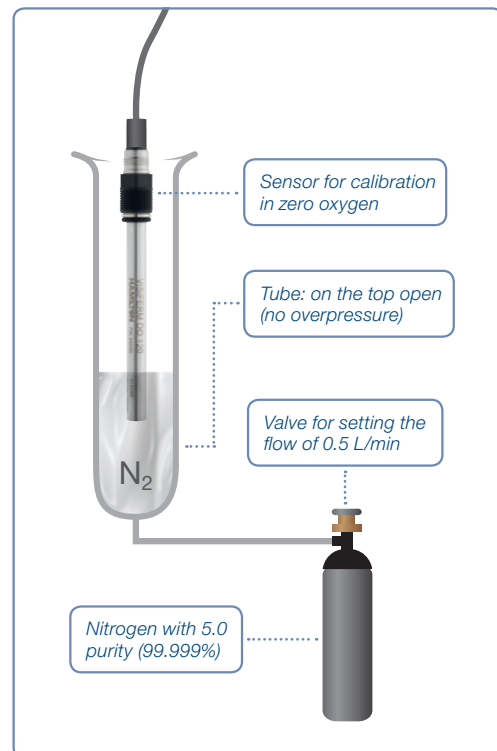

Figure 21: Zero point calibration setup.



### 7.3.3 Calibration in Air (Calibration Point Air)

- 1) Select the sensor to calibrate in "Network View".
- 2) Go in System and select "Operator Level".
- 3) Log in an appropriate Operator Level (Administrator or Specialist). More details in chapter 5.2.
- 4) Go to "Calibration" and select "Calibration Point Air".
- 5) Hold the sensor for at least three minutes under stable conditions in air over stirred water to account for humidity (Figure 22).
- 6) Select the calibration command "Auto" and press "Apply".
- 7) Verify the Calibration status in air. It should indicate "Calibration successful".



Figure 22: Calibration setup in saturated medium.

**NOTE:** Calibration with air-saturated water is less accurate due to the slow saturation process of air in water.

**NOTE:** The value of the saturated oxygen concentration at different temperatures, different pressures and air humidity play an important role for the calibration of dissolved oxygen. VisiFerm DO refers to a concentration in water saturated air and from the factory settings of atmospheric pressure of 1013 mbar at 25°C.

## 7.4 Product calibration

The product calibration is an in-process calibration procedure in order to adjust the measurement to specific process conditions. Product calibration is an additional calibration procedure to a standard calibration.

If product calibration is activated, the VisiFerm DO calibration curve is calculated from the data of last calibration at point 1 and from the data of the product calibration (Figure 23). In order to restore the original standard calibration curve, the product calibration can be at any time by selecting on the Product calibration command "cancel". A new standard calibration cancels a product calibration as well.

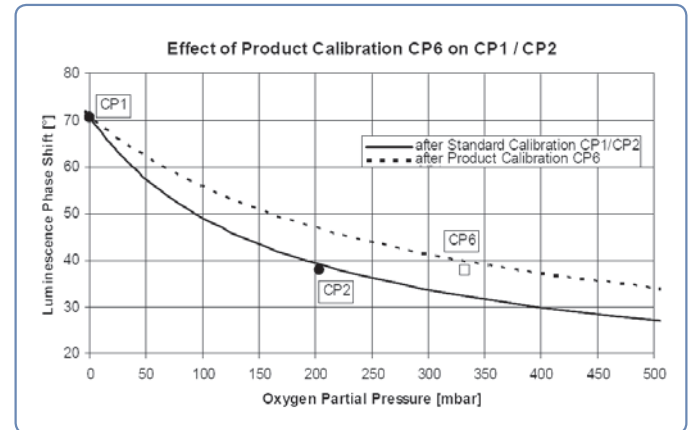

Figure 23: Effect of a product calibration (CP6) on an existing standard calibration function based on the Zero Point Calibration (CP 1) and the Air Calibration (CIP 2).

**NOTE:** The product calibration is possible for DO values in the range of 2 to 55 %-vol (20 – 550 mbar pO<sub>2</sub>).

A product calibration is performed as follows:

- 1) Connect the sensor to HDM.
- 2) Select the sensor to calibrate in "Network View".
- 3) Go in System and select "Operator Level".
- 4) Log in an appropriate Operator Level (Administrator or Specialist). More details in chapter 5.2.
- 5) Go to Calibration and select "Calibration Point Product".
- 6) Select under product calibration command Initialize and press Apply.
- 7) Perform an initial measurement while taking a sample from the process.
- 8) Perform a laboratory measurement of the sample at the same temperature as it was measured in the process.
- 9) Assign the laboratory value in the HDM to the value of the Initial measurement (Product value to assign). This new DO value is accepted and automatically active, if the difference between initial measurement and laboratory values is not greater than 20 %-sat units.
- 10) Verify the Calibration status in product calibration. It should say active + assigned.

**NOTE:** Alternatively, the product calibration may be performed with a field device on side the measuring point.



## 7.5 Cleaning

This chapter outlines a manual cleaning procedure for the care and maintenance of optical dissolved oxygen (ODO) sensors including a procedure for the cleaning the sensing membrane in particular.

### Cleaning the Sensor

Carry out the cleaning procedure as follows:

- 1) Remove sensor from the measuring setup.
- 2) Check if the ODO Cap is mounted firmly on the shaft.
- 3) Soak a dust-free cloth or tissue paper with water and wipe the wetted parts with it. Thoroughly rinse the wetted parts and the sensing membrane with deionised water afterwards.
- 4) Dry the wetted parts with a clean dust-free cloth or tissue and store the sensor in dry and dark conditions (ODO Caps are light-sensitive).
- 5) If the sensing-membrane on the front of the cap is contaminated with oil, grease or other organic matter, soak a clean dust-free cloth with isopropyl alcohol. Rinse residual isopropyl alcohol immediately from the membrane with deionised water and gently wipe over the membrane.
- 6) After cleaning always perform a new calibration before carrying out measurements. (See chapter 7.3 in the corresponding Operating Instruction Manual)

**⚠ ATTENTION! Cleaning, assembly and maintenance should be performed by personnel trained in such work. Do not use any abrasive tissues or cleaning materials and do not use any cleaning chemicals other than described above. Before removing the sensor from the measuring setup, always make sure that the setup is pressure-less and cold and that no process medium can be accidentally spilled. When removing and cleaning the sensor, it is recommended to wear safety glasses and protective gloves.**

## 8 Troubleshooting

### 8.1 Sensor Self-Diagnostic

VisiFerm DO sensors provide a self-diagnostic functionality to detect and identify the most common sensor malfunctions. Both interfaces, analog 4–20 mA or digital Modbus, may provide warning and error messages. The analog 4–20 mA interface can be configured according to the NAMUR recommendations to indicate an abnormal event (See Chapter 5.2.3). Use HDM for monitoring the sensor status and for troubleshooting. The following types of messages are provided by the self-diagnosis function.

**NOTE:** Errors cannot be ignored and corrective action is immediately necessary.

**NOTE:** Warnings can be ignored but the warning will be displayed continuously until the corrective action is successfully completed.

**NOTE:** For additional information about the sensor status and the diagnostics features refer to the sensor operation instruction manual or the programmer's manual.

#### 8.1.1 Warnings

Warning	Cause / Solution
DO reading below lower limit	The oxygen reading is too low (DO < 0%-sat). Make a new zero-point calibration (Chapter 7.3.2).
DO reading above upper limit	The oxygen reading is too high (DO > 300 %-sat). Make a new calibration in oxygen saturated medium. (See chapter 7.3.3). If not successful, replace the sensor cap.
DO reading unstable	If continuously happening, use a new cap or check the process regulation. If the problem still appears, call our Technical Support.
T reading below lower limit	The temperature is below the user defined measurement temperature range. If the process temperature is outside this range, the sensor will not perform DO readings.
T reading above upper limit	The temperature is above the user defined measurement temperature range. If the process temperature is outside this range, the sensor will not perform DO readings.
Measurement not running	The measurement interval is set to 0 or the measurement temperature is out of the range.
DO calibration recommended	Perform a calibration in order to ensure reliable measurement (Chapter 7.3).
DO last calibration not successful	The last calibration failed. The sensor is using the old successful calibration values. In order to ensure reliable measurement perform a new calibration (Chapter 7.3).
DO replace sensor cap	Replace the ODO Cap and calibrate the sensor cap sensor. This warning remains active as long as the sensor quality is below 35%. Make sure that after new cap replacement the sensor reaches at least 60% cap quality. See chapter 7 for replacement conditions. The quality indicator takes sensor and cap into account.

Warning	Cause / Solution
4–20 mA value below 4 mA	The measurement value is below the lower limit of the 4–20 mA interface output. Reconfigure the 4–20 mA interface (Chapter 5.2.8).
4–20 mA value above 20 mA	The measurement value is above the upper limit of the 4–20 mA interface output. Reconfigure the 4–20 mA interface (Chapter 5.2.8).
4–20 mA current set-point not met	The 4–20 mA interface is not able to regulate the current requested for the current measurement value according to your 4–20 mA interface configuration. Check the 4–20 mA wiring and supply voltage (Chapter 5.3.4).
Sensor supply voltage too low	The sensor supply voltage is too low for the sensor to operate correctly. Ensure stable supply voltage within the sensors specifications.
Sensor supply voltage too high	The sensor supply voltage is too high for sensor to operate correctly. Ensure stable supply voltage within the sensors specifications.

### 8.1.2 Errors

Errors (failures)	Cause / Solution
DO reading failure	Sensor cap is missing or the sensor is broken.
DO p(O <sub>2</sub> ) exceeds air pressure	Measured partial pressure of oxygen is higher than the air pressure set by the operator. Reconfigure the air pressure parameter (Chapter 5.2.5).
T sensor defective	The internal temperature sensor is defect, please call our Technical Support.
DO sensor cap missing	The DO sensor cap has been removed. Do not immerse the sensor in a measurement solution. Mount an ODO Cap and calibrate the sensor prior measurement (Chapter 6).
Red channel failure	Measurement channel failure. Please call our Technical Support.
Sensor supply voltage far too low	The sensor supply voltage is below 6 V. Please check your power supply.
Sensor supply voltage far too high	The sensor supply voltage is above 40 V. Please check your power supply.
Temperature reading far below min	The measured temperature is below the operation temperature.
Temperature reading far above max	The measured temperature is above the operation temperature.

## 8.2 Getting Technical Support

If a problem persists even after you have attempted to correct it, contact Hamilton's Customer Support: Please refer to the contact information at the back of this operating instruction.

## 8.3 Returning VisiFerm DO for Repair

Before returning a VisiFerm DO sensor to Hamilton for repair, contact our Customer Service (see Chapter 8.2) and request a Returned Goods Authorization (RGA) number.

Do not return a VisiFerm DO sensor to Hamilton without an RGA number. This number assures proper tracking of your sensor. VisiFerm DO sensors that are returned without an RGA number will be sent back to the customer without being repaired.

Decontaminate the VisiFerm DO sensor and remove health hazards, such as radiation, hazardous chemicals, infectious agents etc. Provide complete description of any hazardous materials that have been in contact with the sensor.

## 9 Disposal



The design of Hamilton sensors optimally considers environmental compatibility. In accordance with the EC guideline 2002/96/EG Hamilton sensors that are worn out or no longer required must be sent to a dedicated collection point for electrical and electronic devices, alternatively, must be sent to Hamilton for disposal. Sensors must not be sent to an unsorted waste disposal point.



此标志表示某一电子和电气产品不含任何有害物质,是绿色环保产品,并且可在废弃之后进行回收,不应随意废弃.

# 10 Ordering Information

Parts below may only be replaced by original spare parts.

## 10.1 VisiFerm DO



Ref	Description	Wetted parts
243505	ODO Cap H2	Stainless steel 1.4435 PTFE (USP Class VI)

**Application:** For fermentation processes where sterilization in place (SIP) is performed in media containing higher amounts of lipophilic compounds. It comes with a hygienic design.

243666		VisiFerm DO	
Code	Interface	Code	Sensor length
1	Arc	1	120
2	ECS	2	160
		3	225*
		4	325
		5	425
		Code	ODO Cap
		1	ODO Cap H0
		2	ODO Cap H2
243666 -			Orderingcode

\*The VisiFerm DO and VisiFerm DO Arc 225 have, in reality, a shaft length of 215 mm. This ensures optimal rinsing in replaceable armatures, such as Retractable.



Ref	Product Name	Length	Interface
355263	Sensor Data Cable VP 8	1 m	4-20 mA/Modbus
355264	Sensor Data Cable VP 8	3 m	4-20 mA/Modbus
355265	Sensor Data Cable VP 8	5 m	4-20 mA/Modbus
355266	Sensor Data Cable VP 8	10 m	4-20 mA/Modbus
355267	Sensor Data Cable VP 8	15 m	4-20 mA/Modbus
355268	Sensor Data Cable VP 8	20 m	4-20 mA/Modbus
355217	Sensor Cable VP 8	1 m	ECS mode
355218	Sensor Cable VP 8	3 m	ECS mode
355219	Sensor Cable VP 8	5 m	ECS mode
355220	Sensor Cable VP 8	10 m	ECS mode
355221	Sensor Cable VP 8	15 m	ECS mode
355222	Sensor Cable VP 8	20 m	ECS mode

**Description:** The Sensor Cable VP 8 – open end is designed for connection to a data recorder, indicator, control unit or PCS (Process Control System) with analog I/O.

## 10.2 Parts and Accessories



Ref	Description	Wetted parts
243515	ODO Cap H0	Stainless steel 1.4435 Silicone (FDA approved and USP Class VI)

**Application:** For general application in biotechnology, water treatment and monitoring as well as in breweries, wineries and soft drink processing.





Ref	Product Name	Connection to
243490-01	Arc USB Power Cable VP 8	Arc Sensor Arc Wi 1G Adapter BT
243490-02	Arc USB Power Cable M12 - 8	Arc Wi 2G Adapter BT
242176	Arc Sensor Cable VP 8	
355339	Arc Wi 2G BT Service Cable 2m	
355289	Arc Wi 2G Service Cable 2m	

**Description:** The Arc USB Power Cable provides power supply via USB port for Arc sensors and digital communication to Hamilton's PC software for monitoring, configuration, calibration and firmware updates.

Ref	Product Name
243470	Arc Wi 2G Adapter BT

**Description:** The Arc Wi 2G Adapter BT not only provides wireless communication via Bluetooth 4.0, but also simplifies analog connection of Arc sensors to the process control system (PCS).

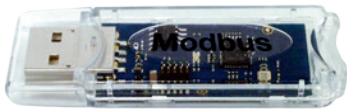

Ref	Product Name
243499	Arc Wireless Converter BT

**Description:** Designed for wireless communication between HDM, VisiFerm DO sensor, mobile devices and GMP Compliance Software.

Ref	Product Name
243690	Arc View Mobile

**Description:** The pre-configured Arc View Mobile, Hamilton's mobile solution for monitoring measurement values, calibrating Arc sensors and configuring various parameters with the unified user interface for pH, DO, Conductivity and ORP. The Arc View Mobile is based on the Samsung Galaxy Tab Active tablet and comes pre-configured with the ArcAir application, app blocker application, power supply cable, instruction manual and Hamilton quick guide.



Ref	Product Name
243460	Arc Wi 1G Adapter BT

**Description:** The Arc Wi 1G Adapter BT provides the wireless communication between the Arc sensors and mobile devices via Bluetooth 4.0.

**ArcAir Application**

Download the ArcAir application from the AppStore and PlayStore.



## 10.3 Services

### Ref Training sessions

243999-12 On-site training (half-day)

**Description:** Imparting of fundamental knowledge about pH/ORP/Conductivity/DO/cell density sensor measuring technology incl. documents and participation confirmation, excl. travel costs

### Ref Service packages

243999-17 PREMIUM service package DO sensor

243999-20 BASIC service package DO sensor

### Ref Service tools

238999-4456 DO service case

### Ref Initial operation and calibration

243999-05 Initial operation per sensor measuring point

**Description:** Sensor parametrization, connection of the sensor cable, calibration of the measuring chain (without transmitter/SPS), check and certification, provision of the measuring and testing equipment as well as orientation of the operator personnel

243999-06 Every further initial operation of the same kind per sensor measuring point

### Ref Qualification (IQ/OQ)

243999-07 IQ/OQ per sensor measuring point

**Description:** Documentation of the initial operation and calibration of the measuring system, provision of the measuring and testing equipment, check and certification (without travel costs)

243999-08 Every further IQ/OQ of the same kind per sensor measuring point

243999-14 IQ/OQ Documentation per sensor gauge incl. report documents and instructions for qualification

### Ref Maintenance

243999-10 Maintenance per DO measuring point

**Description:** Check of the response behavior, calibration with air and nitrogen 5.0, replacement of the electrolytes, cleaning of the internal body, check of the temperature probe, check of the sensor quality with VisiFerm DO, incl. calibration certificate

243999-13 Every further maintenance of the same kind per sensor measuring point

 **NOTE:** These services are only available in the following locations: Europe, Africa and China.







© 2017 Hamilton Bonaduz AG. All rights reserved.  
Windows is a registered trademark or trademark of Microsoft Corporation in the United States and/or other countries.

REF 624156/05 — 03/2017

# HAMILTON®

Web: [www.hamiltoncompany.com](http://www.hamiltoncompany.com)

USA: 800-648-5950

Europe: +41-58-610-10-10

#### Hamilton Americas & Pacific Rim

4970 Energy Way  
Reno, Nevada 89502 USA  
Tel: +1-775-858-3000  
Fax: +1-775-856-7259  
[sales@hamiltoncompany.com](mailto:sales@hamiltoncompany.com)

#### Hamilton Europe, Asia & Africa

Via Crusch 8  
CH-7402 Bonaduz, Switzerland  
Tel: +41-58-610-10-10  
Fax: +41-58-610-00-10  
[contact.pa.ch@hamilton.ch](mailto:contact.pa.ch@hamilton.ch)

To find a representative in your area, please visit [www.hamiltoncompany.com](http://www.hamiltoncompany.com).

This guide may be available in other languages.  
Visit [www.hamiltoncompany.com](http://www.hamiltoncompany.com) for more information.